

2408i

Universal Process Indicator and Alarm Unit



Accurate, stable measurement of temperature, pressure, level, flow and other process variables is provided by the 2408i universal indicator. An optional second process value input allows the average, difference, minimum or maximum of two values to be displayed. Large red or green displays ensure good visibility in high and low ambient lighting.

Temperature linearization functions for nine thermocouple types and Pt100 resistance thermometers are selectable. Other input linearizations can be factory downloaded.

Strain gauge and pressure sensor inputs can be energized from an internal 5 or 10Vdc supply. An automatic calibration routine is provided to remove zero and span offsets.

For liquid level measurement using pressure sensors, a custom 15-point fit can be applied to the input signal to give an accurate displayed value.

Features

- Four alarm setpoints - for plant protection and operating warning
- Serial communications - for supervisory monitoring and data acquisition
- DC retransmission - fully isolated retransmission to remote control and monitoring equipment

Rear terminal connections

Model 2408i

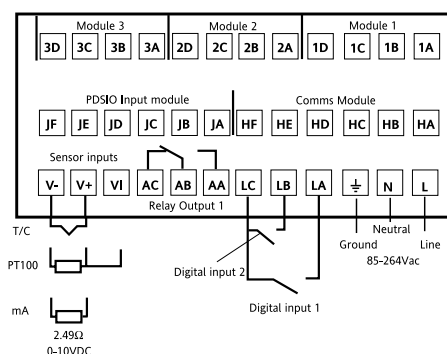

Ideal for

- temperature indication
- pressure, flow and level
- differential measurement
- weighing platforms and strain gauges
- process protection/monitoring

Specifications

Dimensions:

96W x 48H x 150D mm

Display:

Red or green, 5 digit 15.9 mm LED

Supply voltages:

85-264Vac, 20-29Vac/dc, 15 watts max.

Operating ambient:

0-55°C, 5-95% RH non-condensing

Inputs:

Single or dual; Nine standard thermocouple types, Pt100, Strain gauge, Linear mV/mA

Sample rate:

9Hz

Relay output ratings:

2A, 264V resistive

Digital communications:

RS232, 2-wire RS485 and 4-wire RS422 Modbus®, Eurotherm ASCII, DeviceNet and Profibus

Panel sealing:

IP65, plug-in from front

Data sheet:

HA026172



Ordering codes

Model Number	Function	Display Color	Supply Voltage	Module 1	Module 2	Module 3	Relay Output 1	Comms Module	PDS Module	Manual
2408i										

Function	Module 1, 2 & 3	Relay Output 1	Comms Module	Manual
AL Indicator/Alarm unit AP Profibus Indicator/Alarm unit	XX None R4 Fitted unconfigured OR Select alarm configuration from table A DC Retransmission D6 Fitted unconfigured First character V- PV retrains S- Setpoint retrains Z- Error retrains Second character -1 0-20mA -2 4-20mA -3 0-5V -4 1-5V -5 0-10V Dual relay (note 2) RR Fitted unconfigured	XX Not fitted RF Fitted unconfigured OR select alarm configuration from Table A Table A Alarm relay configuration (note 1) Non-latched alarm FH High alarm FL Low alarm DB Dev. band alarm DL Dev. low alarm DH Dev. high alarm RA Rate-of-change alarm Latched alarm HA High alarm LA Low alarm BD Dev. band alarm WD Dev. low alarm AD Dev. high alarm RT Rate-of-change alarm NW New alarm	XX Module not fitted RS232 A2 Fitted unconfigured AM Modbus protocol AE El-Bisynch protocol* RS485 (2-wire) Y2 Fitted unconfigured YM Modbus protocol YE El-Bisynch protocol* RS422 (4-wire) F2 Fitted unconfigured FM Modbus protocol FE El-Bisynch protocol* Profibus Module PB High speed RS485 DeviceNet® DN DeviceNet * Not available with Profibus units	XXX No manual ENG English FRA French GER German NED Dutch SPA Spanish SWE Swedish ITA Italian Note 1: By default, alarm 1 will be assigned to relay output 1 and alarms 2, 3 and 4 to modules 1, 2 and 3 respectively. Note 2: The allocation of alarms to the dual relay outputs is performed in configuration by the customer.

Configuration of Main Input				Config of 2nd Analog Input (requires D5 in Module 3)						
Sensor Input	Setpoint Min	Setpoint Max	Display Units	Digital Input 1	Digital Input 2	2nd DC Input	PV Function	2nd Input Display Min	2nd Input Display Max	Config Options
	note 6	note 6				note 7		note 8	note 8	

Sensor Input	Setpoint Min	Setpoint Max	Display Units	Config Options
Standard Sensor Inputs				
J Thermocouple	Min	Max	°C	
K Thermocouple	-210	1200		
T Thermocouple	-200	1372		
L Thermocouple	-200	400		
N Thermocouple	-200	900		
N Thermocouple-Nicrosil/Nisil	-200	1300		
R Thermocouple-Pt/Pt13%Rh	-50	1700		
S Thermocouple-Pt /Pt10%Rh	-50	1768		
B Thermocouple-Pt/Pt30%Rh -6%Rh	0	1820		
P Platinel II Thermocouple	0	1369		
Z RTD/PT100 DIN 43760	-200	850		
Factory Downloaded Input				
C Thermocouple - W5%Re/W26%Re (Hoskins)	0	2319		
D Thermocouple - W3%Re/W25%Re	0	2399		
E Thermocouple	-250	1000		
1 Ni/Ni18%Mo Thermocouple	0	1399		
2 Pt20%Rh/Pt40%Rh Thermocouple	0	1870		
3 W/W26%Re (Engelhard) Thermocouple	0	2000		
4 W/W26%Re (Hoskins) Thermocouple	0	2010		
5 W5%Re/W26%Re (Engelhard) Thermocouple	10	2300		
6 W5%Re/W26%Re (Bucose) Thermocouple	0	2000		
7 Pt10%Rh/Pt40%Rh Thermocouple	200	1800		
8 Exergen K80 I.R. pyrometer	-45	650		
Process Inputs (Scaled to setpoint min and max)				
M -9.99 to 80.00mV linear	-999	9999		
Y 0 to 20mA linear (note 4)	-999	9999		
A 4 to 20mA linear (note 4)	-999	9999		
W 0 to 5Vdc linear	-999	9999		
G 1 to 5Vdc linear	-999	9999		
V 0 to 10Vdc linear	-999	9999		

Note 3:
Triple contact or logic inputs can be configured, by the user, for any of the functions listed under Digital Inputs 1 and 2.

Note 4:
The triple logic outputs can be configured as alarm outs or as telemetry outs via digital comms.

Note 5:
By default, the transducer supply for input 1 will be installed in module position 2 and the transducer supply for input 2 in module position 1.

Note 6:
Setpoint min and max: Include the decimal points required in the displayed value; up to one for temperature inputs, up to two for process inputs.

Note 7:
Select code required from the Sensor Input table.

Note 8:
These two fields are used to scale the 2nd DC Input if it is a linear process input, otherwise it should be left blank.

Note 9:
For mA inputs, a 1% 2.49ohm current sense resistor is supplied as standard. If greater accuracy is required a 0.1% resistor can be ordered as part number: SUB2K/249R.1

Example ordering code

2408i - AL - GN - VH - RR - RR - XX - XX - YM - XX - ENG - K - 0 - 1000 - C - AC - KL

2408i, Indicating alarm unit, green display, 85 to 264Vac, Dual relay, Dual relay, RS485, Modbus® comms, English manual, Type K thermocouple, 0 to 1000°C, Alarm acknowledge, Keylock